



SOLUZIONI PER IL RECYCLING
SOLUTIONS FOR RECYCLING



BUTTI

PENSATO PER DURARE



 **SCOPE INDUSTRIALI**
INDUSTRIAL BROOMS **4**

SCOPE MODELLO INDUSTRIAL
BROOMS MOD. INDUSTRIAL 4

SCOPE PALA
BLADE BROOM 7

SCOPE MODELLO UNIVERSAL
BROOMS MOD. UNIVERSAL 8

SCOPE MODELLO ECO STRONG
BROOMS MOD. ECO STRONG 10

SCOPE MODELLO ECO UNIVERSAL
BROOMS MOD. ECO UNIVERSAL 12

 **SCOPE MAGNETICHE**
MAGNETIC BROOMS **14**

SCOPE MAGNETICHE
MAGNETIC BROOMS 14

 **TRAMOGGIA PORTA "BIG-BAG"**
"BIG-BAG" HOPPER **15**

TRAMOGGIA PORTA "BIG-BAG"
"BIG-BAG" HOPPER 15

 **CESOIE CAIMAN**
CAIMAN SHEARS **16**

CESOIE CAIMAN
CAIMAN SHEARS 16

TAGLIAFUSTI
DRUMS DEHEADER 16

 **SPACCAMOTORI MULTIFUNZIONE**
MULTIFUNCTION ENGINE CRUSHER **17**

SPACCAMOTORI MULTIFUNZIONE
MULTIFUNCTION ENGINE CRUSHER 17

 **PELACAVI**
CABLE STRIPPING MACHINE **18**

PELACAVI
CABLE STRIPPING MACHINE 18

 **CONTENITORI IN METALLO**
METAL CONTAINERS **19**

CONTENITORI IN METALLO
METAL CONTAINERS 19

 **VASCHE E ASSORBENTI**
WASHING AND ABSORBENT **20**

VASCHE DI LAVAGGIO
WASHING TANKS 20

ASSORBENTE GRANULARE
GRANULAR ABSORBENT 20

 **BIDONI E POMPE**
BINS AND SPRAYERS **21**

BIDONI CARRELLATI
WHEELED BINS 21

POMPE
SPRAYERS 21

CONTENITORI RIBALTABILI "PERTUTTO"
TIPPING CONTAINERS "PERTUTTO" 22

 **CONTENITORI RIBALTABILI**
TIPPING CONTAINERS **22**

CONTENITORI RIBALTABILI "PERTUTTO" per grandi volumi
TIPPING CONTAINERS "PERTUTTO" for big volumes 22

CONTENITORI RIBALTABILI "PERTUTTO" per carrello elevatore elettrico timonato
TIPPING CONTAINERS "PERTUTTO" for powered stackers 23

 **ANTI GHIACCIO**
DEICING **24**

SPAZZANEVE, SPARGISALE, FRESANEVE
SNOWPLOUGH, SALT SPREADER, SNOW BLOWER 24

BUTTI



PROGETTIAMO CON ESPERIENZA, COSTRUIAMO CON PROFESSIONALITÀ

Progettiamo e realizziamo attrezzature per movimentare e contenere ogni tipo di materiale, rendendo più veloce e sicuro il lavoro in vari settori. Possiamo proporre le soluzioni innovative che ci differenziano perché non ci siamo mai accontentati di limitarci a "produrre", ma abbiamo sempre dato grande importanza alla fase di progetto.

Il nostro catalogo non offre solo i prodotti che il mercato richiede, ma punta soprattutto a proporre soluzioni ad esigenze che ancora non hanno una risposta: la nostra forza è la continua innovazione, la costante ricerca di qualità, la grande flessibilità tecnica e commerciale che ci pone come interlocutore privilegiato per le aziende che cercano soluzioni efficaci ed immediate.

WE DESIGN WITH EXPERIENCE, WE BUILD WITH PROFESSIONALISM

We design and manufacture equipment to handle and contain all types of materials, making work faster and safer in various sectors. We can propose innovative solutions that differentiate us because we have never contented ourselves with merely "producing", but we have always given great importance to the project phase. Our catalogue does not only offer the products that the market requires, but aims above all to offer solutions to needs that do not have an answer yet: our strength is the continuous innovation, the constant research for quality, the great technical and commercial flexibility that makes us a privileged interlocutor for companies looking for effective and immediate solutions.

////// I NOSTRI CONTATTI OUR CONTACTS:

Via Mayer 13 - 24034 Cisano Bergamasco (BG) - Italy

Tel. +39 035 787300 - + 39 035787005 - Fax +39 035787322

butti@butti.it - www.butti.it



30 ANNI DI ESPERIENZA

MODERNO STABILIMENTO SU UN'AREA DI 10.000 METRI QUADRI

REPARTO INTERNO RICERCA E SVILUPPO

MAGAZZINO CON PRODOTTI IN PRONTA CONSEGNA

REPARTO INTERNO LAVORAZIONE E REALIZZAZIONE PRODOTTI FINITI

REPARTO INTERNO MARKETING E COMUNICAZIONE

NORMATIVE DI RIFERIMENTO: D.LGS 81/2008 - EN 14502-1 - EN 13155

NB: Le immagini dei prodotti sono puramente indicative e potrebbero pertanto non essere perfettamente rappresentative delle caratteristiche del prodotto. La BUTTI si riserva la facoltà di modificare in qualsiasi momento e senza alcun preavviso l'esecuzione e le dimensioni dei prodotti illustrati.



////// DOVE SIAMO OUR LOCATION:

Ci trovate tra Lecco e Bergamo, facilmente raggiungibili da Monza e Milano You can find us between Lecco and Bergamo, easily reachable from Monza and Milan

IL NOSTRO LAVORO MIGLIORA IL VOSTRO LAVORO

Le tre linee di prodotto che proponiamo affrontano settori diversi – edilizia, industria, recycling – ma hanno in comune la necessità di strutture solide ed affidabili. La nostra trentennale esperienza ci consente di impostare le linee di produzione assicurando un costante controllo, dal progetto alla finitura. Per questo motivo i nostri prodotti non sono un costo per l'azienda, ma un investimento per migliorare sicurezza e produttività.

OUR WORK IMPROVES YOUR WORK

The three product lines we offer address different sectors - construction, industry, recycling - but they have in common the need of solid and reliable structures. Our thirty years of experience allow us to set up production lines ensuring constant control, from design to finishing. For this reason, our products are not a cost for the company, but an investment to improve safety and productivity.

30 YEARS OF EXPERIENCE

A MODERN PLANT ON AN AREA OF 10,000 SQUARE METERS

INTERNAL RESEARCH AND DEVELOPMENT DEPARTMENT

WAREHOUSE WITH PRODUCTS READY ON STOCK

INTERNAL DEPARTMENT FOR PROCESSING AND CONSTRUCTION OF FINISHED PRODUCTS

INTERNAL MARKETING AND COMMUNICATION DEPARTMENT

REFERENCE REGULATIONS: D.LGS 81/2008 - EN 14502-1 - EN13155



Scopa Industrial Compact
Industrial broom Compact



MODELLO MODEL	DIMENSIONI - DIMENSIONS (mm)			N° DI FILI No. OF WIRES	FILE - ROWS	TARA - TARE (Kg)	SPAZZOLE BRUSHES
	L	P	H				
863C20	2000	500	440	16800	3	212	Acciaio Steel

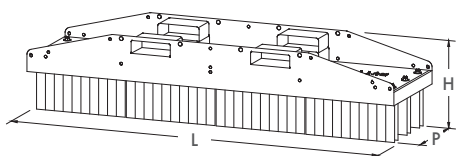

QUOTE SEDI FORCHE
FORK SEATS DIMENSIONS



Scopa Industrial Classic
Industrial broom Classic

MODELLO MODEL	DIMENSIONI - DIMENSIONS (mm)			N° DI FILI No. OF WIRES	FILE - ROWS	TARA - TARE (Kg)	SPAZZOLE BRUSHES
	L	P	H				
865C20	2000	1000	430	33600	6	380	Acciaio Steel

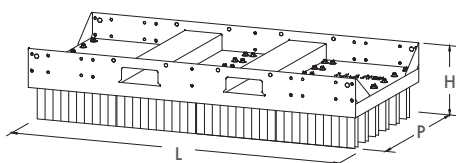

QUOTE SEDI FORCHE
FORK SEATS DIMENSIONS

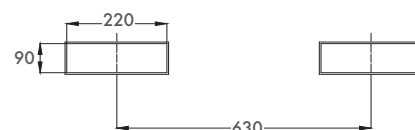

Scopa Industrial Large
Industrial broom Large

MODELLO MODEL	DIMENSIONI - DIMENSIONS (mm)			N° DI FILI No. OF WIRES	FILE - ROWS	TARA - TARE (Kg)	SPAZZOLE BRUSHES
	L	P	H				
865C25	2500	1000	430	42000	6	476	Acciaio Steel

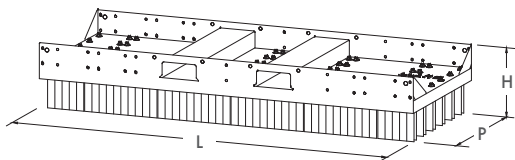

QUOTE SEDI FORCHE
FORK SEATS DIMENSIONS

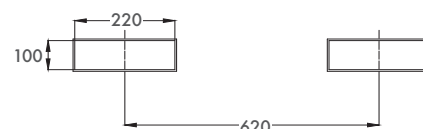

Scopa Industrial Extralarge
Industrial broom Extralarge

MODELLO MODEL	DIMENSIONI - DIMENSIONS (mm)			N° DI FILI No. OF WIRES	FILE - ROWS	TARA - TARE (Kg)	SPAZZOLE BRUSHES
	L	P	H				
865C30	3000	1000	430	50400	6	566	Acciaio Steel

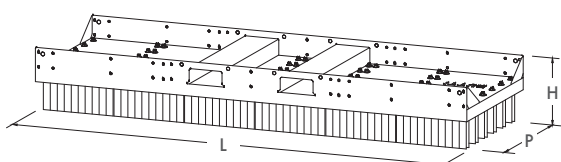

QUOTE SEDI FORCHE
FORK SEATS DIMENSIONS

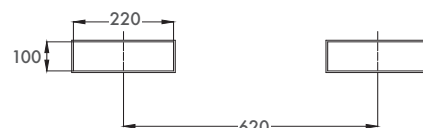

Kit spazzole di ricambio
Replacement kit



Lunghezza 50 cm - Length 50 cm
in acciaio per tutti i modelli di scope Butti
in steel for every Butti's brooms model

Lunghezza 100 cm - Length 100 cm
in acciaio per tutti i modelli di scope non prodotte dalla Butti
in steel for every brooms models not produced by Butti

FACILI E VELOCI DA
SOSTITUIRE E MONTARE
EASY AND FAST TO
REPLACE AND MOUNT

Attacco per pala gommata
Attachment for wheel loader



Attacco forca pinza per modelli Classic, Large e Extralarge
Clamp attachment for Classic, Large and Extralarge models

MODELLO MODEL	DIMENSIONI - DIMENSIONS (mm)		
	L	P	H utile - useful
868F0750B	1150	925	600

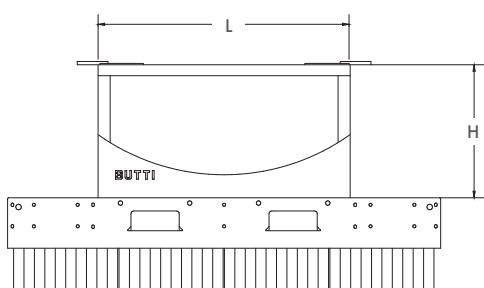

Lame regolabili in acciaio per spinta materiali per modelli Classic, Large e Extralarge
Adjustable steel blades to push scrap for Classic, Large and Extralarge models

MODELLO MODEL	DIMENSIONI - DIMENSIONS (mm)	
	L	H
868LR420B	2000	400
868LR425B	2500	400
868LR430B	3000	400
868LR620B	2000	600
868LR625B	2500	600
868LR630B	3000	600



**REGOLABILI
ADJUSTABLE**

A RICHIESTA - ON DEMAND

**LAME ROBUSTE | ROBUST BLADES
SPESSORE 15mm | 15mm THICKNESS
REGOLABILI | ADJUSTABLE**

Kit "sistema di riduzione polvere" - DRS per scope Industrial modelli Classic, Large e Extralarge
 Kit "dust reduction system" - DRS for Industrial broom model Classic, Large and Extralarge

**SISTEMA DUST
 RIDUZIONE/REDUCTION
 POLVERE/SYSTEM**

MODELLO MODEL	VOLUME (Liter)	MODELLO SCOPIA BROOM MODEL
868C0320	300	Industrial Classic
868C0325	300	Industrial Large
868C0330	300	Industrial Extralarge



Il sistema di riduzione polvere è un kit composto da una cisterna da 300 litri con rubinetto e raccordi in ottone, irrigatore in inox.
 Come protezione del sistema è previsto il montaggio di una lama regolabile.

*The "dust reduction system" kit is composed of a 300 lt watertank with brass discharge valve and connection, stainless steel sprinkler.
 An adjustable blade is to be installed as a protection of the system.*



Scopa pala utilizzabile con carrello elevatore con piastra rotante per forche, raschiante intercambiabile
Blade broom usable with forklift rotating fork clamp, interchangeable scraper



MODELLO MODEL	DIMENSIONI - DIMENSIONS (mm)			N° DI FILI No. OF WIRES	FILE - ROWS	TARA - TARE (Kg)	SPAZZOLE BRUSHES
	L	P	H				
865SP20 Classic	2000	1000	1290	33600	6	675	Acciaio Steel
865SP25 Large	2500	1000	1290	42000	6	835	Acciaio Steel
865SP30 Extralarge	3000	1000	1290	50400	6	1000	Acciaio Steel

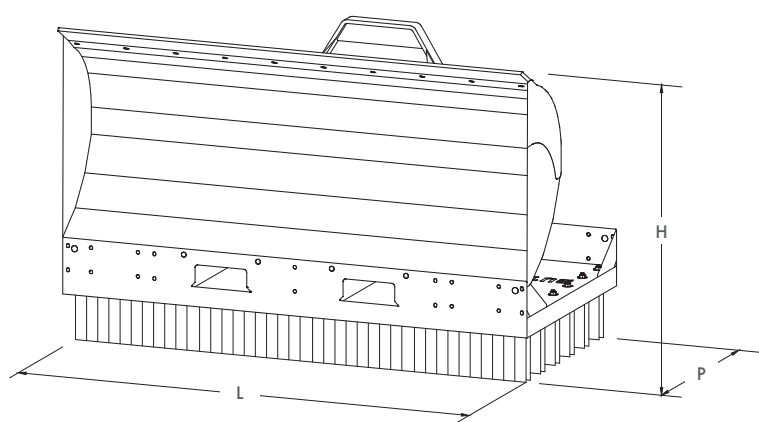

Scopa Universal Compact
Universal broom Compact

 Video disponibile
Video available

MODELLO MODEL	DIMENSIONI - DIMENSIONS (mm)			N° DI FILI No. OF WIRES	FILE - ROWS	TARA - TARE (Kg)	SPAZZOLE BRUSHES
	L	P	H				
863UC20	2000	500	370	16800	3	161	Acciaio Steel

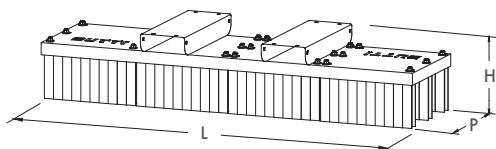

QUOTE SEDI FORCHE
FORK SEATS DIMENSIONS



Scopa Universal Classic
Universal broom Classic

MODELLO MODEL	DIMENSIONI - DIMENSIONS (mm)			N° DI FILI No. OF WIRES	FILE - ROWS	TARA - TARE (Kg)	SPAZZOLE BRUSHES
	L	P	H				
865UC20	2000	800	380	28000	5	268	Acciaio Steel

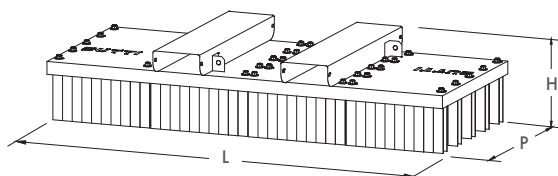

QUOTE SEDI FORCHE
FORK SEATS DIMENSIONS

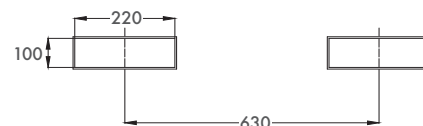

Scopa Universal Large
Universal broom Large

MODELLO MODEL	DIMENSIONI - DIMENSIONS (mm)			N° DI FILI No. OF WIRES	FILE - ROWS	TARA - TARE (Kg)	SPAZZOLE BRUSHES
	L	P	H				
865UC25	2500	800	380	35000	5	318	Acciaio Steel

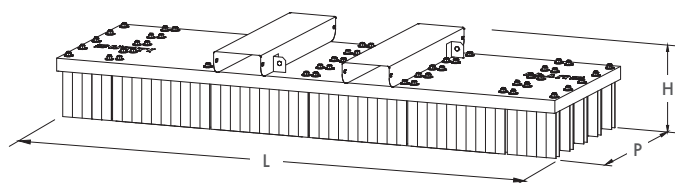

QUOTE SEDI FORCHE
FORK SEATS DIMENSIONS

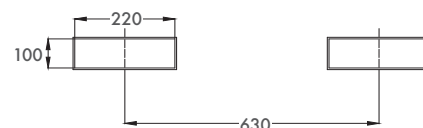

Kit spazzole di ricambio
Replacement kit



FACILI E VELOCI DA
SOSTITUIRE E MONTARE
EASY AND FAST TO
REPLACE AND MOUNT

Lunghezza 50 cm - Length 50 cm
in acciaio per tutti i modelli di scope Butti
in steel for every Butti's brooms model

Lunghezza 100 cm - Length 100 cm
in acciaio per tutti i modelli di scope non prodotte dalla Butti
in steel for every brooms models not produced by Butti

Attacco forca pinza per modelli Classic e Large
Clamp attachment for Classic and Large models

MODELLO MODEL	DIMENSIONI - DIMENSIONS (mm)		
	L	P	H utile - useful
868F0750U	1150	790	600

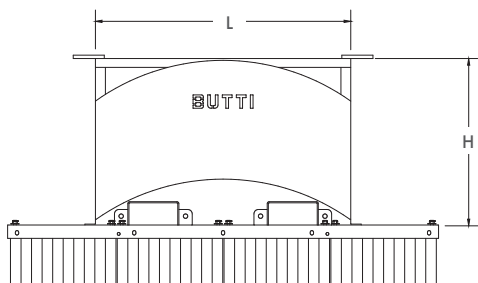

Lame regolabili in acciaio per spinta materiali per modelli Classic e Large
Adjustable steel blades to push scrap for Classic and Large models

MODELLO MODEL	DIMENSIONI - DIMENSIONS (mm)	
	L	H
868LR420B	2000	400
868LR425B	2500	400

**REGOLABILI
ADJUSTABLE**



Scopa Eco Strong Compact Eco Strong broom Compact



MODELLO MODEL	DIMENSIONI - DIMENSIONS (mm)			N° DI FILI No. OF WIRES	FILE - ROWS	TARA - TARE (Kg)	SPAZZOLE BRUSHES
	L	P	H				
866S0520	2000	500	470	24000	5	146	Polipropilene Polypropylene

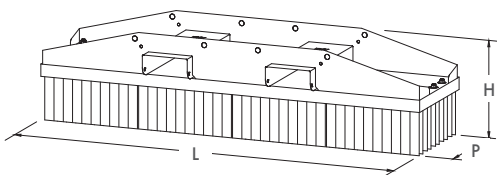

QUOTE SEDI FORCHE
FORK SEATS DIMENSIONS

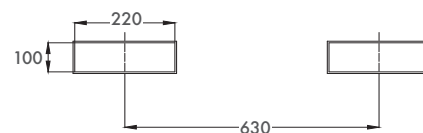

Scopa Eco Strong Classic Eco Strong broom Classic

MODELLO MODEL	DIMENSIONI - DIMENSIONS (mm)			N° DI FILI No. OF WIRES	FILE - ROWS	TARA - TARE (Kg)	SPAZZOLE BRUSHES
	L	P	H				
866S1020	2000	1000	500	43800	8	272	Polipropilene Polypropylene

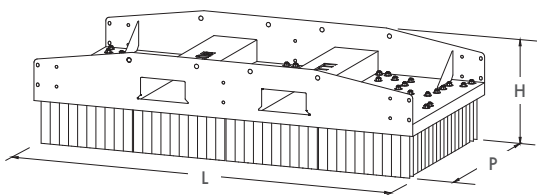

QUOTE SEDI FORCHE
FORK SEATS DIMENSIONS

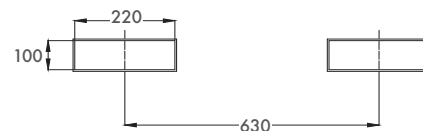

Scopa Eco Strong Large Eco Strong broom Large

MODELLO MODEL	DIMENSIONI - DIMENSIONS (mm)			N° DI FILI No. OF WIRES	FILE - ROWS	TARA - TARE (Kg)	SPAZZOLE BRUSHES
	L	P	H				
866S1025	2500	1000	500	53400	8	310	Polipropilene Polypropylene

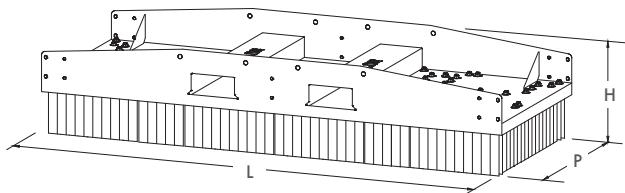

QUOTE SEDI FORCHE
FORK SEATS DIMENSIONS

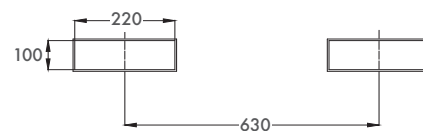

Scopa Eco Strong Extralarge Eco Strong broom Extralarge

MODELLO MODEL	DIMENSIONI - DIMENSIONS (mm)			N° DI FILI No. OF WIRES	FILE - ROWS	TARA - TARE (Kg)	SPAZZOLE BRUSHES
	L	P	H				
866S1030	3000	1000	500	64200	8	356	Polipropilene Polypropylene

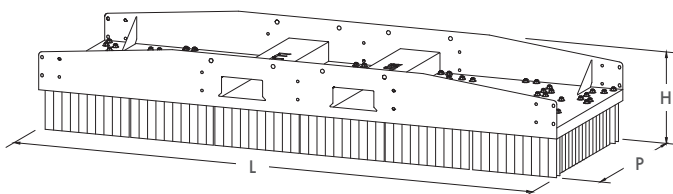

QUOTE SEDI FORCHE
FORK SEATS DIMENSIONS

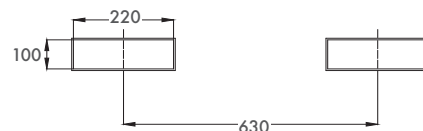

Kit spazzole di ricambio
Replacement kit

Spazzole in PP di alta qualità
High quality PP brushes

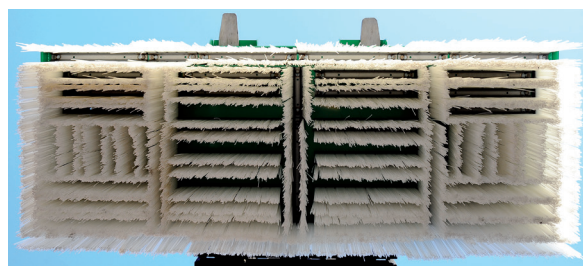

Lunghezza 50 cm - Length 50 cm
in PP per tutti i modelli di scope Butti
in PP for every Butti's brooms model

Lunghezza 100 cm - Length 100 cm
in PP per tutti i modelli di scope non prodotte dalla Butti
in PP for every brooms models not produced by Butti

**FACILI E VELOCI DA
SOSTITUIRE E MONTARE
EASY AND FAST TO
REPLACE AND MOUNT**

Le spazzole sono in polipropilene di alta qualità, montate trasversalmente per una migliore aderenza durante le operazioni di pulizia. Le spazzole sono inoltre progettate per essere altamente resistenti, maneggevoli e per resistere nel tempo all'usura.

Brushes are in "PP high quality" mounted transversally to have a better adherence during the cleaning. These are also designed to be sturdy and manageable and to resist for more time to mechanical stresses during the use.

Attacco forza pinza per modelli Classic, Large e Extralarge
Clamp attachment for Classic, Large and Extralarge models

MODELLO MODEL	DIMENSIONI - DIMENSIONS (mm)		
	L	P	H utile - useful
868F0750S	1150	900	600

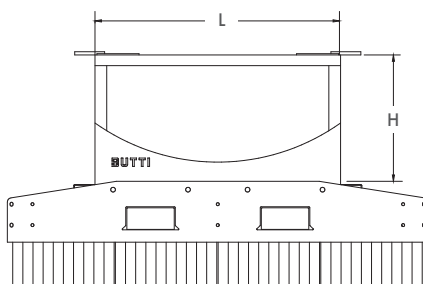
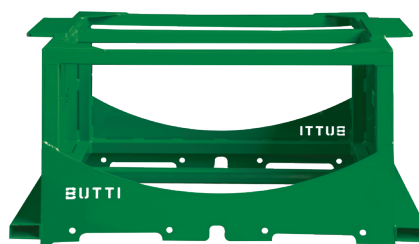

Lame regolabili in acciaio per spinta materiali per modelli Classic, Large e Extralarge
Adjustable steel blades to push scrap for Classic, Large and Extralarge models

MODELLO MODEL	DIMENSIONI - DIMENSIONS (mm)	
	L	H
868LR420V	2000	400
868LR425V	2500	400
868LR430V	3000	400

**REGOLABILI
ADJUSTABLE**



Scopa Eco Universal Compact
Eco Universal broom Compact

MODELLO MODEL	DIMENSIONI - DIMENSIONS (mm)			N° DI FILI No. OF WIRES	FILE - ROWS	TARA - TARE (Kg)	SPAZZOLE BRUSHES
	L	P	H				
866N0520	2000	500	370	14400	3	106	Polipropilene Polypropylene

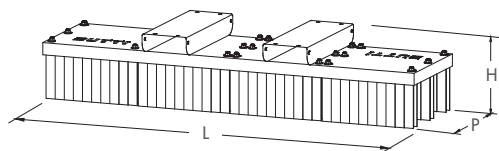

QUOTE SEDI FORCHE
FORK SEATS DIMENSIONS

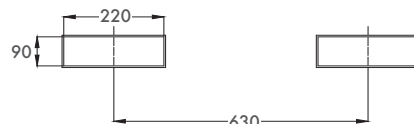

Scopa Eco Universal Classic
Eco Universal broom Classic

MODELLO MODEL	DIMENSIONI - DIMENSIONS (mm)			N° DI FILI No. OF WIRES	FILE - ROWS	TARA - TARE (Kg)	SPAZZOLE BRUSHES
	L	P	H				
866N1020	2000	800	380	24000	5	176	Polipropilene Polypropylene

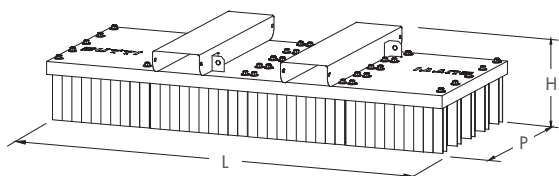

QUOTE SEDI FORCHE
FORK SEATS DIMENSIONS

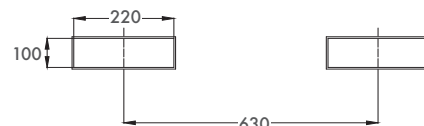

Scopa Eco Universal Large
Eco Universal broom Large

MODELLO MODEL	DIMENSIONI - DIMENSIONS (mm)			N° DI FILI No. OF WIRES	FILE - ROWS	TARA - TARE (Kg)	SPAZZOLE BRUSHES
	L	P	H				
866N1025	2500	800	380	30000	5	213	Polipropilene Polypropylene

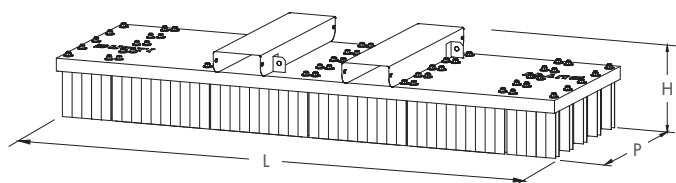

QUOTE SEDI FORCHE
FORK SEATS DIMENSIONS

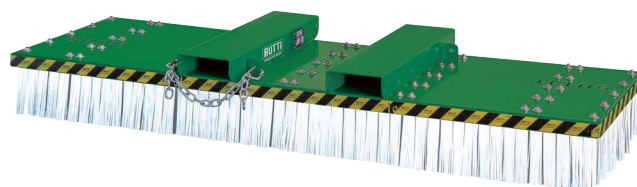
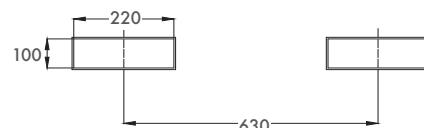

Kit spazzole di ricambio
Replacement kit



FACILI E VELOCI DA
SOSTITUIRE E MONTARE
EASY AND FAST TO
REPLACE AND MOUNT

Lunghezza 50 cm - Length 50 cm
in PP per tutti i modelli di scope Butti
in PP for every Butti's brooms model

Lunghezza 100 cm - Length 100 cm
in PP per tutti i modelli di scope non prodotte dalla Butti
in PP for every brooms models not produced by Butti

Attacco forca pinza per modelli Classic e Large
Clamp attachment for Classic and Large models

MODELLO MODEL	DIMENSIONI - DIMENSIONS (mm)		
	L	P	H utile - useful
868F0750U	1150	790	600

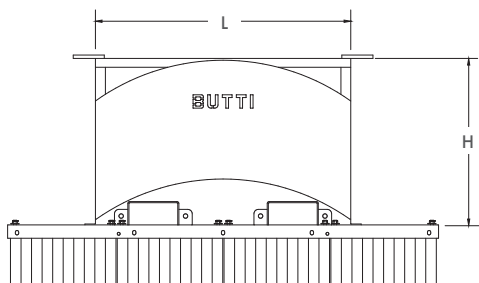

Lame regolabili in acciaio per spinta materiali per modelli Classic e Large
Adjustable steel blades to push scrap for Classic and Large models

MODELLO MODEL	DIMENSIONI - DIMENSIONS (mm)	
	L	H
868LR420V	2000	400
868LR425V	2500	400

**REGOLABILI
ADJUSTABLE**



SCOPE MAGNETICHE | MAGNETIC BROOMS

Robusta struttura in acciaio inox che consente la raccolta di piccoli componenti ferrosi mediante piastra magnetica.
 Sturdy steel frame allows the collection of small iron parts through the magnetic plate.



Scopa magnetica con ruote e sistema di apertura facilitata tramite leva
 Magnetic broom with wheels and easy opening system by lever

MODELLO MODEL	DIMENSIONI - DIMENSIONS (mm)		
	L	P	H
867M0515RF	1500	920	500
867M0525RF	2500	920	500

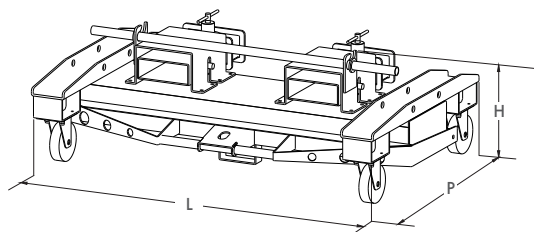

MASSIMA PRATICITÀ D'UTILIZZO grazie alle ruote girevoli in Inox e all'altezza fissa di 110 mm dal piano magnetico a terra.
NUOVO MAGNETE DOPPIA FORZA: capacità di trazione più di **100 KG** di sfridi ferrosi.
SISTEMA ESCLUSIVO AMMORTIZZANTE per pavimenti irregolari.

MAXIMUM EASE OF USE thanks to the swiveling wheels in stainless steel and to the fixed height of 110 mm between the magnet and the floor.
NEW MAGNET DOUBLE STRENGTH: pulling force more than **100 KG** of ferrous scraps.
UNIQUE SHOCK ABSORBING SYSTEM for uneven floors.

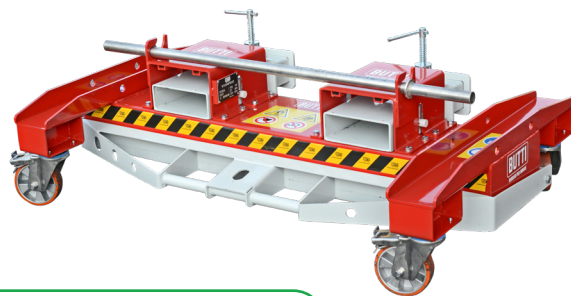

**ESCLUSIVO SISTEMA AMMORTIZZANTE
 UNIQUE SHOCK ABSORBING SYSTEM**



**TRAZIONE OLTRE 100 KG
 PULLING FORCE 100 KG**

Scopa magnetica con sistema di apertura facilitata tramite leva
 Magnetic broom with easy opening system by lever

MODELLO MODEL	DIMENSIONI - DIMENSIONS (mm)		
	L	P	H
867M0515	1500	600	280
867M0525	2500	600	300

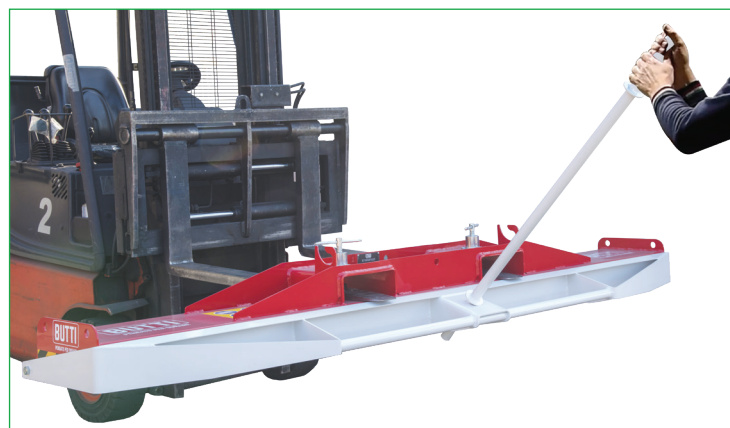
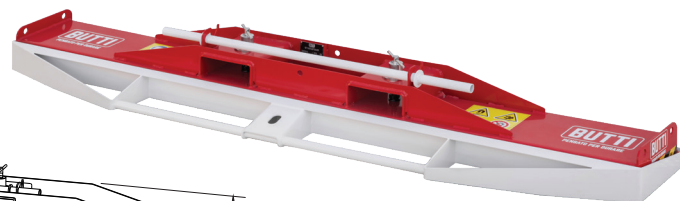
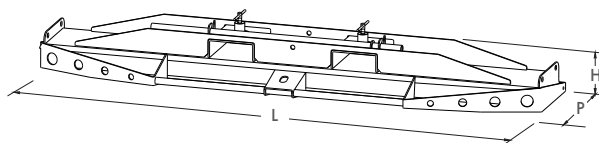

QUOTE SEDI FORCHE
 FORK SEATS DIMENSIONS
 867M0515 - 867M0515RF

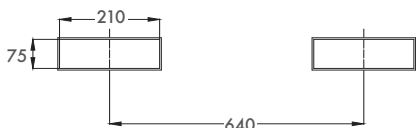

QUOTE SEDI FORCHE
 FORK SEATS DIMENSIONS
 867M0525 - 867M0525RF

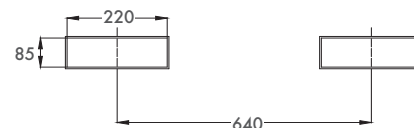

Pratica e robusta tramoggia in acciaio, facilita l'insacco di qualsiasi tipo di materiale.
 Handy and sturdy steel hopper, simplifies the tilling in a bag of any type of material.



Tramoggia porta Big-Bag fissa Fixed Big-Bag hopper

MODELLO MODEL	DIMENSIONI - DIMENSIONS (mm)							TARA - TARE (Kg)	PORTATA LOAD CAPACITY (Kg)
	L1xP1	L2xP2	L3xP3 utile-useful	H1	H2	H3	H4		
873TB16F	1600x1400	1675x1675	1440x1240	2330	2930	1530	2130	295	2000

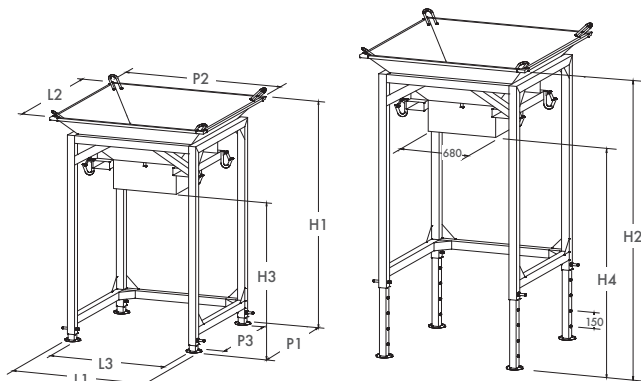

- ✓ AMPIO IMBUTO DI CARICO
WIDE FUNNEL INSERTION
- ✓ ALTEZZA REGOLABILE CON PASSI DA 150 mm
ADJUSTABLE HEIGHT WITH 150 mm STEPS
- ✓ ROBUSTA STRUTTURA IN ACCIAIO
STURDY STEEL STRUCTURE
- ✓ GANCI SALDATI PER FISSARE IL BIG-BAG
AGEVOLMENTE
WELDED HOOKS TO FIX EASILY THE BIG-BAG
- ✓ DIMENSIONI BOCCA DI SCARICO 680x680 mm
DISCHARGE DIMENSIONS 680x680 mm

QUOTE SEDI FORCHE
 FORK SEATS DIMENSIONS

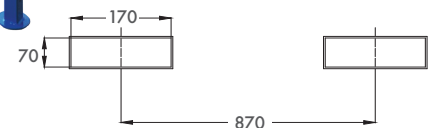

Tramoggia porta Big-Bag smontabile, facilita la movimentazione del sacco pieno Removable Big-Bag hopper, facilitates the handling of the full bag

MODELLO MODEL	DIMENSIONI - DIMENSIONS (mm)							TARA - TARE (Kg)	PORTATA LOAD CAPACITY (Kg)
	L1xP1	L2xP2	L3xP3 utile-useful	H1	H2	H3	H4		
873TB16	1600x1400	1675x1675	1440x1240	2330	2930	1530	2130	355	2000

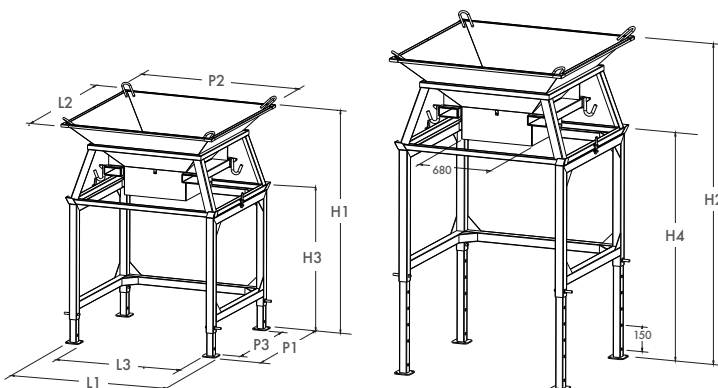

- ✓ AMPIA BOCCA DI CARICO
WIDE INSERTION FUNNEL
- ✓ ALTEZZA REGOLABILE CON PASSI DA 150 mm
ADJUSTABLE HEIGHT WITH 150 mm STEPS
- ✓ ROBUSTA STRUTTURA IN ACCIAIO
STURDY STEEL STRUCTURE
- ✓ GANCI SALDATI PER FISSARE IL BIG-BAG
AGEVOLMENTE
WELDED HOOKS TO FIX EASILY THE BIG-BAG
- ✓ DIMENSIONI BOCCA DI SCARICO 680x680 mm
DISCHARGE DIMENSIONS 680x680 mm

QUOTE SEDI FORCHE
 FORK SEATS DIMENSIONS

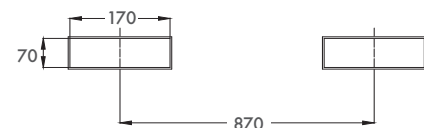

Sacco "Big Bag" "Big Bag"



MODELLO MODEL	DIMENSIONI - DIMENSIONS (mm)			PORTATA LOAD CAPACITY (Kg)
	L	P	H	
99C30-	900	900	1000	1000
			1200	1200
			1500	1500
			1700	2000

Cesoie caiman per il taglio di metalli di recupero Caiman shears to cut recyclable metals



MODELLO MODEL	Lunghezza lama Blade length	Motore elettrico Electric motor	Forza di taglio Cutting strength	Premi lamiera Plate rehearsal	Pressione Pressure	Cicli a vuoto Empty cycles	Capacità serbatoio Tank load	Dimensioni Dimesions	Peso in ordine di lavoro Weight in work order	Capacità di taglio Cutting capacity	Capacità di taglio Cutting capacity	Capacità di taglio Cutting capacity	Capacità di taglio Cutting capacity
										—	○	□	○
	mm	kw	ton		bar		lt	L x P x H (mm)	kg	S275JR	S275JR	S275JR	S275JR
869C150	150	1,8	17	idraulico/ manuale hydraulic/ manual	180	12	80	560x640x1300	350	6x80	φ 25	20x20	φ 27 SP.4
869C250	250	4	50	idraulico hydraulic	180	15	120	900x1350x1300	840	8x100	φ 30	25x25	φ 42 SP.6
869C340	340	4	55	idraulico hydraulic	220	15	120	1200x1500x1400	1100	10x130	φ 40	30x30	φ 48 SP.8
869C500	500	7,5	94	idraulico hydraulic	250	13	200	1280x1750x1400	1450	12x150	φ 50	40x40	φ 70 SP.8

Video disponibile
Video available

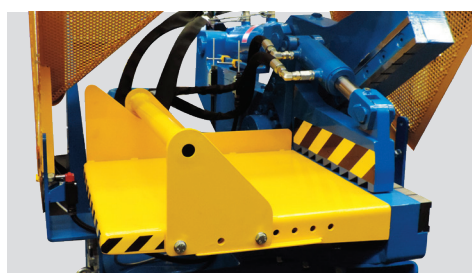
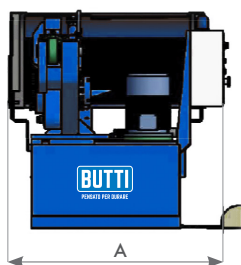
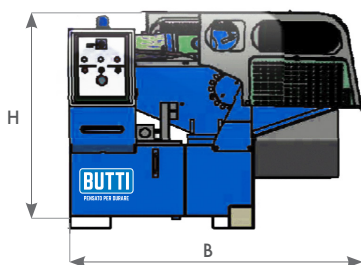

Doppia sicurezza:
robusto piano di lavoro
con fermo barra
regolabile
Double safety:
sturdy plan of work with
adjustable bar to block
the materials to cut

- Alimentazione elettrica: 400 V. 50 HZ
- Ciclo manuale
- Corsa controllabile tramite micro regolabili
- Power supply: 400 V. 50 HZ
- Manual cycle
- Stroke controlled by micro

Tagliafusti per la rimozione dei coperchi dei fusti metallici Drums deheader for the removal of metal drum covers

MODELLO
MODEL

925

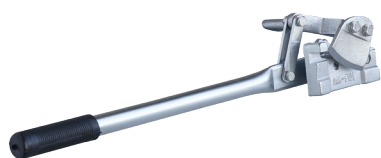

Macchina spaccamotori multifunzione EMTS-1000/3 Multifunction engine crusher EMTS-1000/3

MODELLO MODEL	DIMENSIONI - DIMENSIONS (mm)			TARA TARE (Kg)	Ø MAX STATORI MOTORI ELETTRICI MAX Ø ELECTRIC MOTOR STATORS mm	TENSIONE DI ALIMENTAZIONE SUPPLY VOLTAGE
	L	P	H			
870EMTS10	2480	1687	3060	2300	400	4 KW+3KW - 400 v. / 50hz

 Video disponibile
Video available

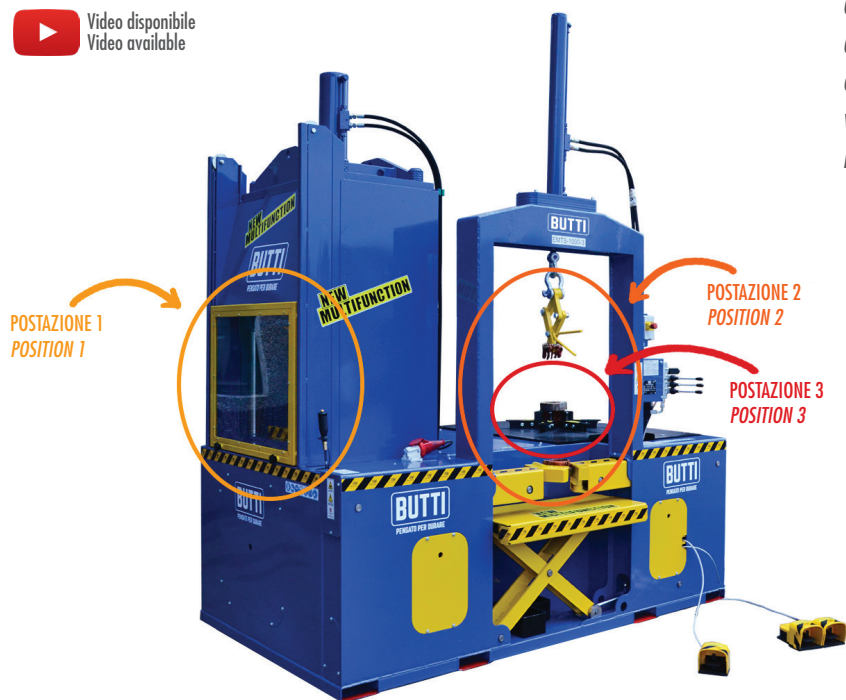

La spaccamotori multifunzione EMTS-1000/3 è stata progettata per rompere le carcasse dei motori elettrici, tagliare gli statori e i trasformatori, al fine di estrarre il rame dagli avvolgimenti dei motori elettrici. Grazie a questo macchinario si ha la possibilità di sfruttare rifiuti, come i motori elettrici, dai quali si può ricavare una risorsa importante, il rame.
The EMTS-1000/3 multifunction engine crusher has been designed to break the casings of electric motors, cut stators and transformers, in order to extract copper from the windings of electric motors. With this machine it is possible to exploit waste, such as electric motors, from which an important resource can be obtained, copper.

**LE POSTAZIONI 1 E 2 SONO DISPONIBILI ANCHE SINGOLARMENTE.
POSITIONS 1 AND 2 ARE ALSO AVAILABLE INDIVIDUALLY.**

POSTAZIONE 1 - POSITION 1 - ARIES

Rottura carcasse motori, taglio statori e trasformatori.
Breaking of the motor casings, cutting stators and transformers.

MODELLO MODEL	DIMENSIONI - DIMENSIONS (mm)			TARA TARE (Kg)	TENSIONE DI ALIMENTAZIONE SUPPLY VOLTAGE
	L	P	H		
870EMMX40	1260	873	1756	1500	4 KW - 400 v. / 50hz



POSTAZIONE 2 - POSITION 2 - SKORPION

Estrazione rame dagli avvolgimenti dei motori elettrici, con pinza.
Copper extraction from the windings of electric motors, with clamp.

MODELLO MODEL	DIMENSIONI - DIMENSIONS (mm)			TARA TARE (Kg)	TENSIONE DI ALIMENTAZIONE SUPPLY VOLTAGE
	L	P	H		
870EMSM10	2470	1127	3060	900	2,2 KW - 400 v. / 50hz

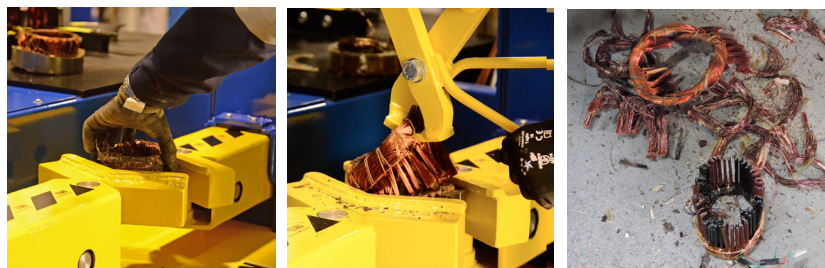

POSTAZIONE 3 - POSITION 3

Estrazione rame dagli avvolgimenti dei motori elettrici, con espulsori.
Copper extraction from the windings of electric motors, with ejectors.

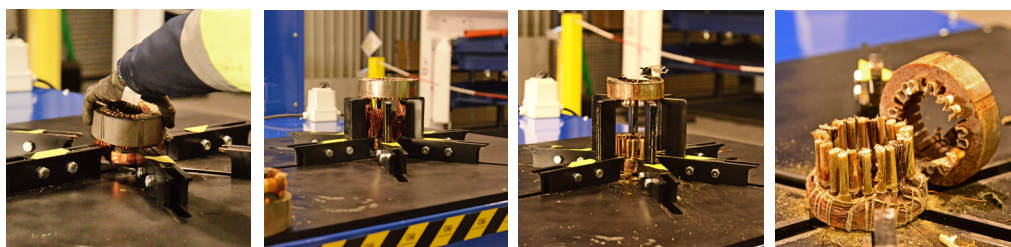

Pelacavi Junior Box, doppio taglio del cavo Cable stripping machine Junior Box, double cable cutting

MODELLO MODEL	Ø CAVI Ø CABLES mm	DIMENSIONI - DIMENSIONS (mm)			TARA TARE (Kg)	TENSIONE DI ALIMENTAZIONE SUPPLY VOLTAGE
		L	P	H		
870P050M	4-40	645	405	525	75	220 v. Monofase / 50hz 220 v. Single phase / 50hz

- ✓ Interruttore magnetotermico a Norma CE
Magnetothermal switch according to CE standard
- ✓ Volantini manuali di regolazione taglio cavo
Handwheels for cable cutting adjustment
- ✓ Motore elettrico per l'azionamento della macchina
Electric motor to drive the machine
- ✓ Carter di protezione in lamiera verniciata
Protective carter in painted metal sheet
- ✓ Struttura portante in acciaio
Supporting structure in steel

MASSIMA SICUREZZA
GRAZIE AI CARTER DI PROTEZIONE
DI INSERIMENTO ED USCITA CAVO
MAXIMUM SAFETY
DUE TO THE PROTECTION CARTERS
OF THE CABLE INSERTION AND EXIT

IN DOTAZIONE: 13 LAME DI RICAMBIO
SUPPLIED WITH: 13 SPARE BLADES

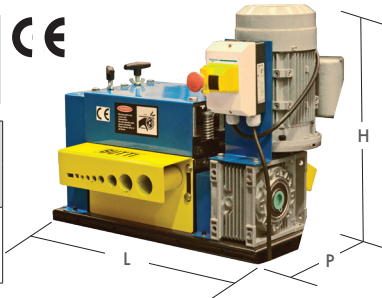

ACCESSORIO A RICHIESTA: CARRELLO
ACCESSORY ON REQUEST: TROLLEY



Macchina pelacavi, doppio taglio del cavo, regolazione delle lame motorizzata Cable stripping machine, double cable cutting, motorized blade adjustment

MODELLO MODEL	Ø CAVI Ø CABLES mm	DIMENSIONI - DIMENSIONS (mm)			TARA TARE (Kg)	VELOCITÀ DI TAGLIO CUTTING SPEED	TENSIONE DI ALIMENTAZIONE SUPPLY VOLTAGE
		L	P	H			
870P100M	6-50	750	920	1210	185	16 metri al minuto 16 meters per minute	400 v. Trifase / 50hz 400 v. Three Phase / 50hz
870P200M	8-80	925	950	1300	250	25 metri al minuto 25 meters per minute	400 v. Trifase / 50hz 400 v. Three Phase / 50hz

- ✓ Doppio taglio del cavo
Double cable cutting
- ✓ Tunnel di ingresso dei cavi da trattare e carteratura di uscita del cavo trattato
Cable entrance and exit tunnels
- ✓ Carter di protezione della zona di taglio
Cutting area safety protection
- ✓ Pannello di controllo operatore e quadro elettrico di controllo macchina
Control panel & machine electrical

Video disponibile
Video available



870P200M

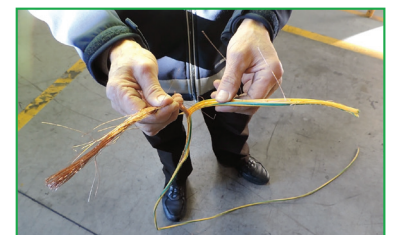

L'operazione della pelacavi consiste nel praticare uno o due tagli in senso longitudinale sulla guaina esterna del cavo. Completata l'operazione di taglio si procede manualmente a "strappare" agevolmente il rame dalla plastica.
The operation of the cable stripping machine consists in making one or two cuts longitudinally on the outer sheath of the cable. Once the cutting operation is completed, the copper is easily "torn" from the plastic by hand.

Contenitori in metallo
Metal containers

MODELLO MODEL	PORTATA LOAD CAPACITY (Kg)	DIMENSIONI - DIMENSIONS (mm)					TARA TARE (Kg)	PESO PIENO CARICO TOTAL FULL LOAD WEIGHT (Kg)
		L	P	H1	H2	H3		
621	600	650	700	450	150	60	30	630
625	2000	1000	800	650	150	100	92	2092
626	1000	1200	800	650	150	60	64	1064
629	500	1700	800	450	150	100	85	585

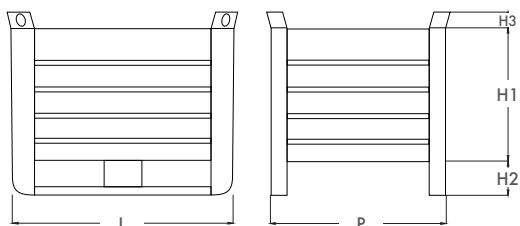

Sovrapposizione statica 3 su 1 a pieno carico.
Static overlap of 3 to 1 at full load.



Contenitori in metallo con sportello
Metal containers with door

MODELLO MODEL	PORTATA LOAD CAPACITY (Kg)	DIMENSIONI - DIMENSIONS (mm)					TARA TARE (Kg)	PESO PIENO CARICO TOTAL FULL LOAD WEIGHT (Kg)
		L	P	H1	H2	H3		
625S	2000	1000	800	650	150	100	99	2099
626S	1000	1200	800	650	150	60	69	1069

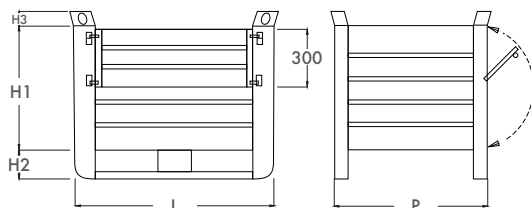

Sovrapposizione statica 3 su 1 a pieno carico.
Static overlap of 3 to 1 at full load.



Contenitori in rete
Mesh containers

MODELLO MODEL	PORTATA LOAD CAPACITY (Kg)	DIMENSIONI - DIMENSIONS (mm)					TARA TARE (Kg)	PESO PIENO CARICO TOTAL FULL LOAD WEIGHT (Kg)
		L	P	H1	H2	H3		
624R	1000	1000	800	650	150	60	50	1050
626R	1000	1200	800	650	150	60	51	1051

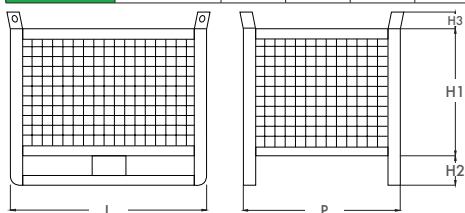

Sovrapposizione statica 3 su 1 a pieno carico.
Static overlap of 3 to 1 at full load.



Contenitori in rete con sportello
Mesh containers with door

MODELLO MODEL	PORTATA LOAD CAPACITY (Kg)	DIMENSIONI - DIMENSIONS (mm)					TARA TARE (Kg)	PESO PIENO CARICO TOTAL FULL LOAD WEIGHT (Kg)
		L	P	H1	H2	H3		
626RS	1000	1200	800	650	150	60	60	1060

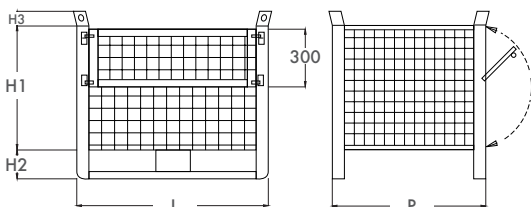

Sovrapposizione statica 3 su 1 a pieno carico.
Static overlap of 3 to 1 at full load.



Vasca di lavaggio Washing tank

MODELLO MODEL	DIMENSIONI - DIMENSIONS (mm)			VOLUME (Liter)
	L	P	H	
900	700	560	810	60
901	1000	560	810	90

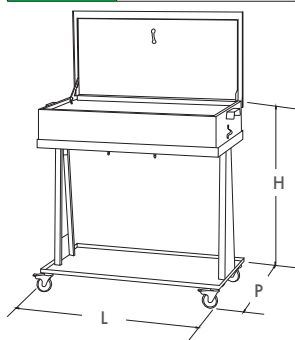

Carrello lavapezzi Parts washing cart

MODELLO MODEL	DIMENSIONI - DIMENSIONS (mm)			VOLUME (Liter)
	L	P	H	
935	1150	705	900	65

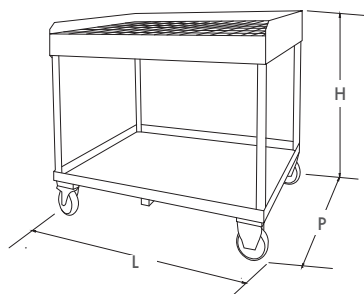

Assorbente granulare per prodotti liquidi e oleosi Granular absorbent for liquid and oily products



MODELLO MODEL	CARATTERISTICHE FEATURES	PEZZI PER BANCALE PIECES ON PALLET
909G0512	Granulare fine 12 Kg (sacco) Fine granular 12 Kg (bag)	60

Video disponibile
Video available

BUTTI
PULIZIE PER BIANCHI

WHITE SORB BUTTI

ASSORBENTE UNIVERSALE - IENIFUO - PER PRODOTTI LIQUIDI E OLEOSI

GRANULARE FINE
Assorbente miscelato naturale
12 Kg G

- Non è un prodotto infiammabile (in caso di incendio non rilascia gas nocivi)
- Non rilascia la sostanza assorbita
- È biodegradabile anche
- Non contiene additivi nocivi
- Non è tossico né aggressivo
- Assorbente universale in grado di assorbire qualsiasi tipologia di prodotto liquido o oleoso

COME SI USA
Applicare il prodotto sul liquido che si vuole assorbire e ridistribuire senza scorie per effetto del battuto (non è necessario l'uso di spazzole o altri strumenti). Non lasciare ristagni. Custodire in contenitore ermetico e in un luogo asciutto.

CAPACITÀ DI ASSORBIMENTO PER SACCO LT 15
Può essere utilizzato all'interno di officine meccaniche, industrie automobilistiche, aeronautiche, petrolifere e chimiche, stabilimenti, stazioni di servizio, strade, autostrade e aree di transito in genere.

Questo prodotto non viene considerato pericoloso nel suo formato di acquisto o nel suo stato di utilizzo e non richiede speciali disposizioni per il suo uso.

SMALTIMENTO: attraverso l'incenerimento o conferimento alla discarica seguendo la regolamentazione in vigore e in base al prodotto assorbito.



Composto granulare assorbente e neutralizzante per acidi Granular absorbent and neutralizer for acids



MODELLO MODEL	CARATTERISTICHE FEATURES
909P0805	Granulare 6 Kg (secchio) Granular 6 Kg (bucket)

BUTTI
PULIZIE PER BIANCHI

ACID SORB BUTTI

COMPOSTO GRANULARE ASSORBENTE E NEUTRALIZZANTE PER ACIDI

6 Kg G

CARATTERISTICO: ACID SORB BUTTI, composto granulare assorbente, in grado di neutralizzare l'acido perossido (H₂O₂) in 20 minuti, con un tempo di reazione di 10 minuti. È biodegradabile e non tossico. È adatto per l'uso in officine meccaniche, industrie automobilistiche, aeronautiche, petrolifere e chimiche, stabilimenti, stazioni di servizio, strade, autostrade e aree di transito in genere.

CAVITÀ NEUTRALIZZANTE DELLA COMPOSIZIONE: 21,4 (10)

INDICAZIONI DI USO:
Contiene un alto contenuto di polimeri idrofili che garantiscono la sicurezza durante l'uso. È adatto per l'uso in officine meccaniche, industrie automobilistiche, aeronautiche, petrolifere e chimiche, stabilimenti, stazioni di servizio, strade, autostrade e aree di transito in genere.

DEFINIZIONE: l'effluente del prodotto è stato verificato dal dipartimento di Scienze Chimiche dell'Università degli Studi di Napoli e ha dimostrato di essere sicuro per l'ambiente.

STOCAGGIO: conservare il prodotto nel contenitore originale in un luogo asciutto.

SEGNALAZIONE: 1023

BUTTI srl - Via Mayer 13 - 20154 Cusano Bergamasco - +39 035 78700 - butti@butti.it - www.butti.it



Bidone carrellato con coperchio per la raccolta differenziata
Wheeled bins with lid for separate waste collection

MODELLO MODEL	DIMENSIONI - DIMENSIONS (mm)			PESO WEIGHT (Kg)	CAPACITÀ DI CARICO LOAD CAPACITY (Kg)	VOLUME (Lt)
	L	P	H			
941L120-	480	550	930	9	60	120
941L240-	580	730	1070	13	116	240

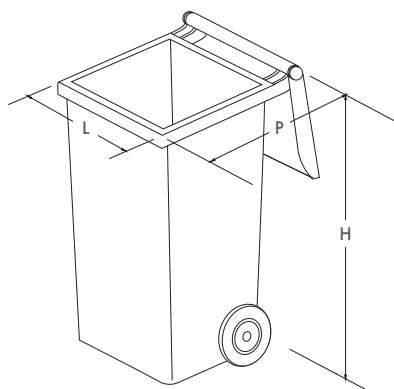

Optional a richiesta
On demand:
 Anello ferma sacco
Blocking bag ring

Optional a richiesta
On demand:
 Kit completo anello
 ferma sacco + pedale
*Complete kit foot
 opening system +
 blocking bag ring*

Colori disponibili
Available colours

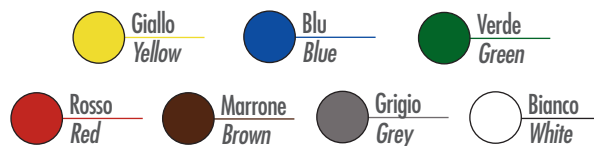

Realizzati in polietilene ad alta densità e dotati di 2 ruote di diametro 200 mm e dotati di una pratica maniglia per facilitarne la movimentazione.

They are made of high-density polyethylene and equipped with 2 wheels of 200 mm diameter and are equipped with a practical handle for easy moving.



ELEKTRO-12
POMPA PROFESSIONALE CON BATTERIA AL LITIO ideale per la sanificazione
LITHIUM BATTERY PROFESSIONAL SPRAYER ideal for sanitizing

MODELLO MODEL	PORTATA LOAD CAPACITY (Lt)
619EL12	12

**PISTOLA CON ATTACCO GIREVOLE
 E GRUPPO FINALE IN OTTONE PROFESSIONALI**
**PROFESSIONAL BRASS DISCHARGE VALVE WITH SWIVEL
 ATTACHMENT AND COMPLETE SPRAYLANCE**



ELEKTRO-15
POMPA A BATTERIA RICARICABILE ideale per la sanificazione
RECHARGEABLE BATTERY SPRAYER ideal for sanitizing

MODELLO MODEL	PORTATA LOAD CAPACITY (Lt)
619EL15	15



POMPA PROFESSIONALE IN ACCIAIO INOX ideale per la sanificazione
PROFESSIONAL STAINLESS STEEL SPRAYER ideal for sanitizing

MODELLO MODEL	PORTATA LOAD CAPACITY (Lt)
619IX	10

**PISTOLA CON ATTACCO GIREVOLE
 E GRUPPO FINALE IN OTTONE PROFESSIONALI**
**PROFESSIONAL BRASS DISCHARGE VALVE WITH SWIVEL
 ATTACHMENT AND COMPLETE SPRAYLANCE**



CONTENITORI RIBALTABILI "PERTUTTO" | TIPPING CONTAINERS "PERTUTTO"

Contenitori ribaltabili "Pertutto" Tipping containers "Pertutto"



Video disponibile
Video available

MODELLO MODEL	DIMENSIONI - DIMENSIONS (mm)									PORTATA LOAD (Kg)	VOLUME (Liter)
	P1	P2	L	H1	H2	H3	A	B	C		
748R	930	720	750	695	850	740	60	180	660	580	280
750R	1250	1000	870	510	665	530	60	180	660	600	300
751R	1490	1130	975	655	875	715	60	180	800	1000	500
752R	1575	1290	1070	745	965	770	60	180	800	1350	750
753R	1680	1400	1070	900	1140	940	60	180	800	1500	1000
756R	1780	1600	1785	1115	1490	1245	90	220	930	1800	2300

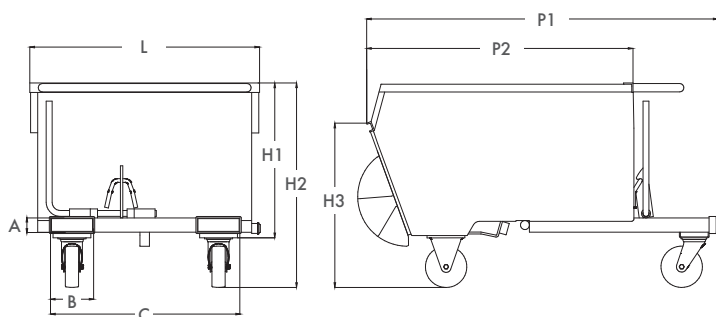

Contenitori ribaltabili "Pertutto" per grandi volumi Tipping containers "Pertutto" for big volumes



MODELLO MODEL	DIMENSIONI - DIMENSIONS (mm)						PORTATA - LOAD (Kg)	VOLUME (Liter)
	P1	P2	L	H1	H2	H3		
77B1800R	1630	1365	1065	920	1760	1160	500	1800
77B2200R	1630	1365	1230	920	1760	1160	600	2200

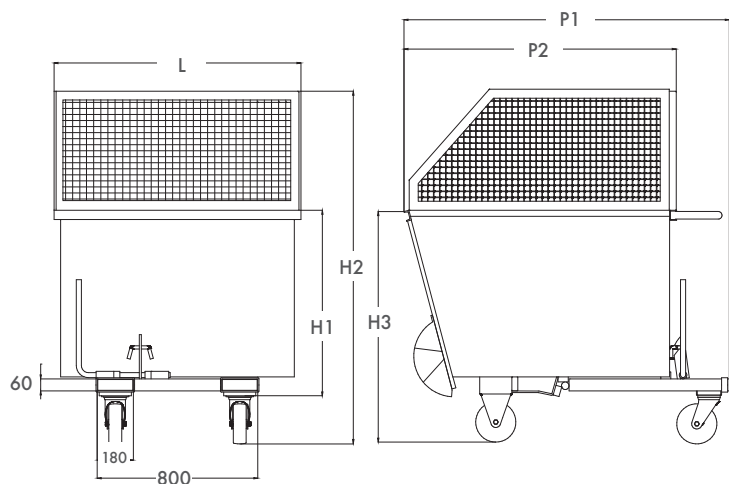

Contenitori ribaltabili "Pertutto" per carrello elevatore elettrico timonato
 Tipping containers "Pertutto" for powered stackers



MODELLO MODEL	DIMENSIONI - DIMENSIONS (mm)							PORTATA - LOAD (Kg)	VOLUME (Liter)
	P1	P2	L1	L2	H1	H2	H3		
748RS	930	720	865	750	695	850	740	580	280
750RS	1250	1000	865	870	510	665	530	600	300
751RS	1490	1130	940	975	655	875	715	1000	500

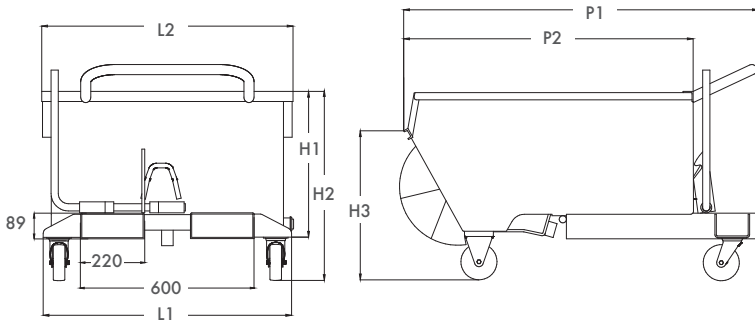

Quote sedi forche
 Fork seats dimensions

MODELLO MODEL	A	B	C
748R - 750R	54	174	480
751R 752R - 753R	54	174	620
756R	81	212	710

MODELLO MODEL	A	B	C
77B1800R 77B2200R	54	174	620

MODELLO MODEL	A	B	C
748RS 750RS - 751RS	81	212	380

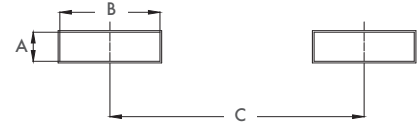

Cilindro idraulico SECURE SYSTEM
 Hydraulic cylinder SECURE SYSTEM



Dalla continua ricerca per la sicurezza negli ambienti di lavoro la Butti ha ideato il nuovo sistema "SECURE SYSTEM": cilindro idraulico, applicato a richiesta sui contenitori ribaltabili "Pertutto" per una maggiore sicurezza. Garantisce lunga vita ai cuscinetti dei montanti del carrello elevatore ed ai contenitori stessi, permettendo un ribaltamento graduale e progressivo senza violenti contraccolpi o cadute accidentali. Il cilindro "Secure System" è montato nella parte sottostante del contenitore; la sua installazione non comporta ingombro nelle dimensioni.

From the ongoing search of safety in workplaces, Butti has devised the new system "SECURE SYSTEM": hydraulic cylinder, which can be applied on request to the tipping containers "Pertutto" to have more safety. It guarantees long lifespan both for forklifts and containers themselves by allowing a gradual and progressive tipping without violent backlashes and accidental falls. The "Secure System" cylinder is placed at the bottom of the container; its installation doesn't change container dimensions.

SPAZZANEVE FISSO con raschiante in acciaio non intercambiabile FIXED SNOWPLOUGH with steel scraper not interchangeable



MODELLO MODEL	DIMENSIONI - DIMENSIONS (mm)			AMMORTIZZATORI SHOCK ABSORBERS	POSIZIONE RASCHIANTE SCRAPER POSITION
	L	P	H		
87814	1415	1330	700	1	20° verso destra 20° on the right

QUOTE SEDI FORCHE
FORK SEATS DIMENSIONS

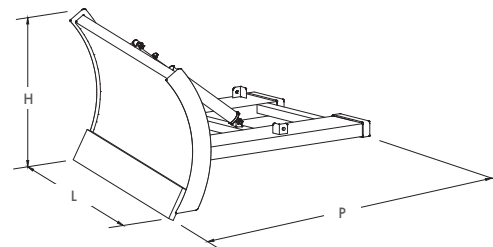
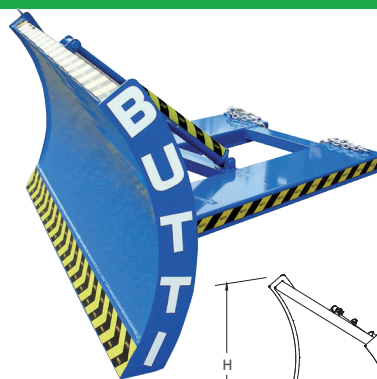
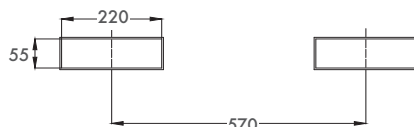

SPAZZANEVE ORIENTABILE con raschiante in poliuretano intercambiabile ADJUSTABLE SNOWPLOUGH with interchangeable polyurethane scraper

MODELLO MODEL	DIMENSIONI - DIMENSIONS (mm)			AMMORTIZZATORI SHOCK ABSORBERS	POSIZIONE RASCHIANTE SCRAPER POSITION	RASCHIANTE SCRAPE
	L	P	H			
87815ORG	1515	1360	740	1	0°-15°-30° verso destra o sinistra on the right or left	Poliuretano Polyurethane
87823ORG	2315	1800	740	2	0°-15°-30° verso destra o sinistra on the right or left	Poliuretano Polyurethane

Mod. 87815ORG
QUOTE SEDI FORCHE
FORK SEATS DIMENSIONS



Mod. 87823ORG
QUOTE SEDI FORCHE
FORK SEATS DIMENSIONS

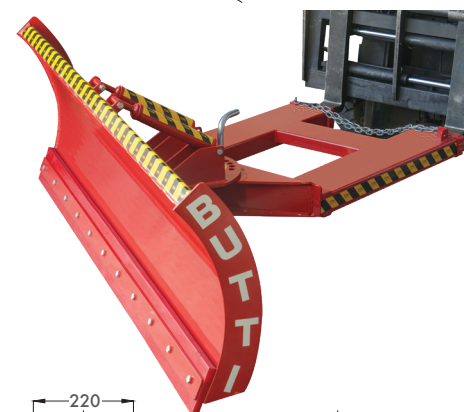
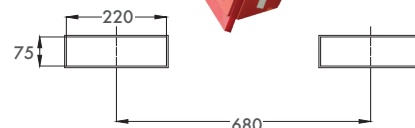

SPARGISALE PROFESSIONALE a mano PROFESSIONAL manual SALT SPREADER



MODELLO MODEL	VELOCITÀ DI LAVORO (Km/h) WORKING SPEED (Km/h)	PORTATA LOAD CAPACITY (Kg)
876K25	1/4	25
876K50	1/4	50



CARRELLO SPARGISALE PROFESSIONALE a traino PROFESSIONAL towing SALT SPREADER



MODELLO MODEL	VELOCITÀ DI LAVORO (Km/h) WORKING SPEED (Km/h)	PORTATA LOAD CAPACITY (Kg)
877K150	10/15	150
877K250	10/15	250



Mod. 877K250 stradale, completo di catarifrangenti
Mod. 877K250 for road, complete with reflectors

PANTHER con turbo fresa PANTHER with snow blower



MODELLO MODEL	DIMENSIONI - DIMENSIONS (mm)			MOTORE ENGINE	VELOCITÀ MOTORE ENGINE SPEED (min)	POTENZA MOTORE ENGINE POWER (kw)
	L	P	H			
879PFD2 Panther	800	700	1240	Motore a scoppio monocilindrico raffreddato ad aria Briggs & Stratton Briggs & Stratton single-cylinder air cooled combustion engine	3000	4,8

MODELLO MODEL	DIMENSIONI - DIMENSIONS (mm)			RAGGIO DI AZIONE ACTION RANGE (mm)
	L	P	H	
879SF70 Turbo fresa Snow blower	740	750	880	700





SOLUZIONI PER IL RECYCLING
SOLUTIONS FOR RECYCLING



PENSATO PER DURARE

BUTTI srl - Via Mayer, 13 | 24034 Cisano Bergamasco (BG) | Tel. +39 035 787300 | butti@butti.it | butti.it